

## J0200 SWINGHAULER

### Balanced Designed Swing Hauler



- Added Safety. The unique frame design eliminates dangerous movement common to top mounted haulers.
- Trunnion mounted frame permits partial orientation forward or aft.
- 24 Inch diameter Stainless Steel sheaves, shim adjustable for use with 5/8" to 1 1/4" size line.
- Low maintenance, sealed, oil lubricated Planetary Gear Drive.
- Galvanized fabricated steel frame.
- Up to 5000 pounds of line pull.
- Galvanized fabricated steel fairlead.



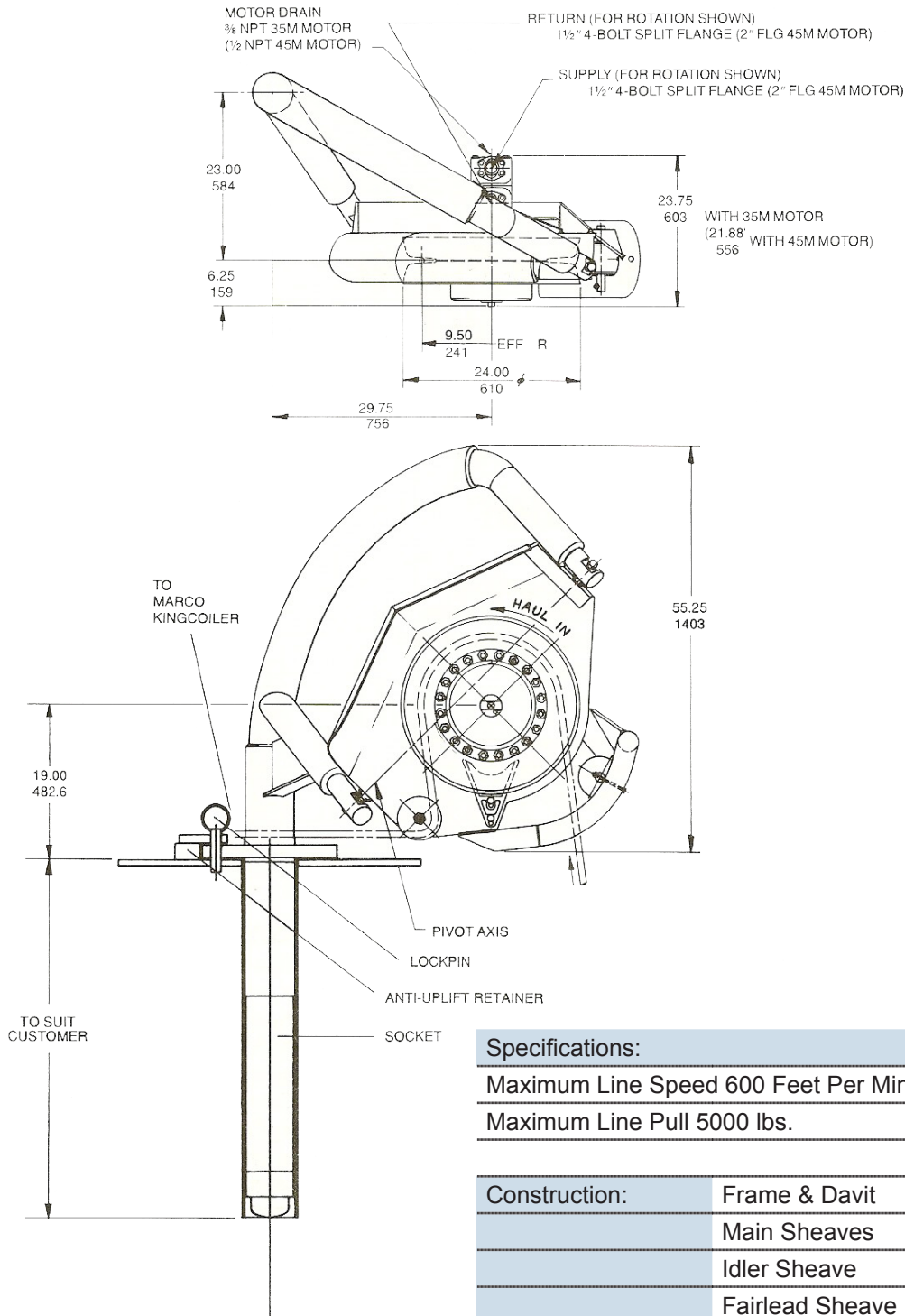

**Specifications:**

Maximum Line Speed 600 Feet Per Minute  
 Maximum Line Pull 5000 lbs.

Construction:	Frame & Davit	Galvanized Fabricated Steel
	Main Sheaves	Cast Bronze or Stainless Steel
	Idler Sheave	Cast Aluminum
	Fairlead Sheave	Cast Stainless Steel
	Splitter	Stainless Steel

Weight:	1450 Lbs
Maximum Line Size	1 Inch
Lubricant:	SAE 90 Multi-Purpose Gear Oil

**Smith Berger Marine, Inc.**  
 7915 10<sup>th</sup> Ave. S., Seattle, WA 98108 USA  
 Tel. 206.764.4650 - Toll Free 888.726.1688 - Fax 206.764.4653  
 E-mail: [sales@smithberger.com](mailto:sales@smithberger.com) - Web: [www.smithberger.com](http://www.smithberger.com)