

J2111 KINGCOILER

Hydraulic powered line coiler.

Maximum speed, minimum effort.

- Faster than manual coiling.
- Produces uniform coils.
- Maintains constant line tension.
- Handles large knots.
- Adjusts automatically to hauling speed.



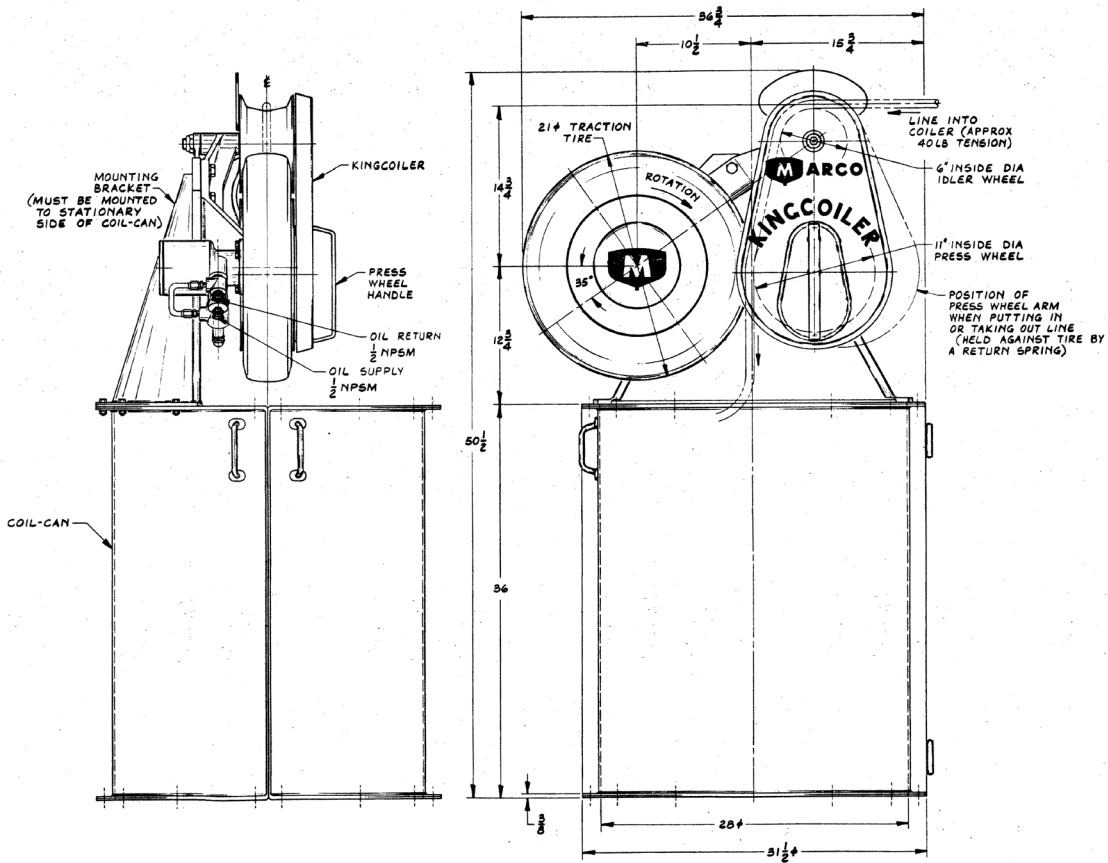
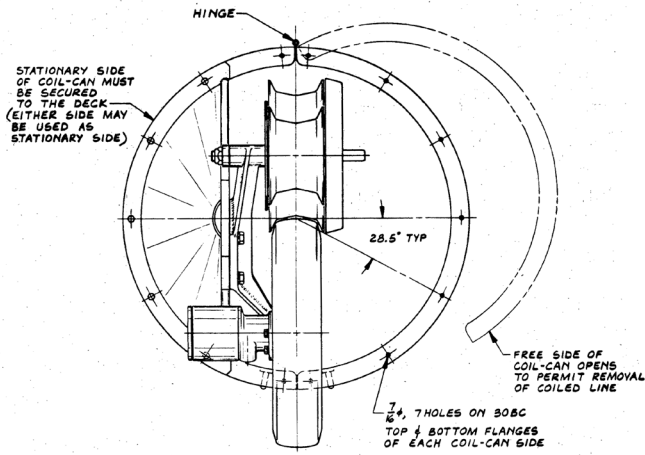

Coiling Speed: 600 FPM

*Speed is based on oil supply of 6GPM @ 300 PSI (15GPM Maximum)

Construction: Frame: Marine coated aluminum can and brackets
 Idler Wheels: Galvanized Steel
 Idler Shafts: Stainless Steel

Weight: 200 Lbs.

Smith Berger Marine, Inc.

7915 10th Ave. S., Seattle, WA 98108 USA

Tel. 206.764.4650 - Toll Free 888.726.1688 - Fax 206.764.4653

E-mail: sales@smithberger.com - Web: www.smithberger.com