

PKW15 PURSE WINCH

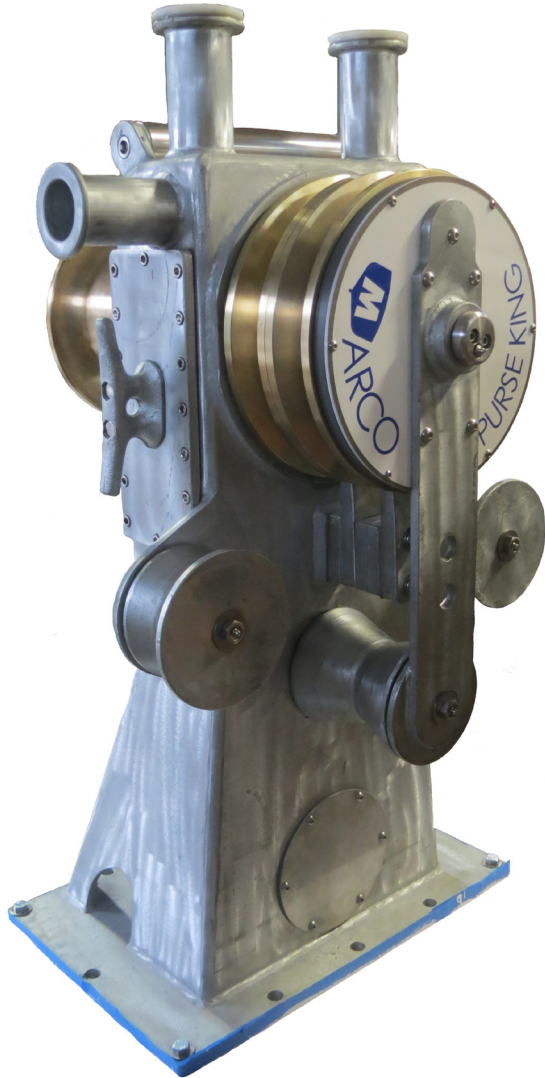

FEATURES

- ▶ Dual Sheave Design
- ▶ No Slippage
- ▶ Easily Passes Splices and Links
- ▶ Backs up Easily Under Tension
- ▶ Up to 5,000 lbs Line Pull
- ▶ Single Capstan
- ▶ Optional Line Transporter
- ▶ For Smaller Salmon Seiners

SAFETY

- ▶ Hands Free Operation
- ▶ E-STOP Emergency Shut Off Switch.

The PKW15 Purse Winch features a unique dual sheave design which eliminates slippage when pursing.

The line wraps first around the inside sheave, then comes around the outer sheave for a second wrap which takes the slack and maintains traction on the line in the inside sheave.

The extra traction provided by the outer sheave allows the operator to stop and reverse the winch to safely pay out line under tension.

The dual sheave design also allows splices, knots and even links to pass through the sheaves safely without slippage.

For further safety the PKW15 features an E-STOP emergency shut off switch on the top horn.

The back side of the winch features a 9" capstan.

The PKW15 is available with three motor options. Your performance will depend upon the hydraulic flow and pressures your boat can provide.

Performance Specifications

Motor	Input Flow	Pull	Line Speed
	GPM	(in Pounds)	Feet Per Minute
19 CID	20	3,200	180
24 CID	30	3,900	198
30 CID	40	5,000	186



PKW15 PURSE WINCH

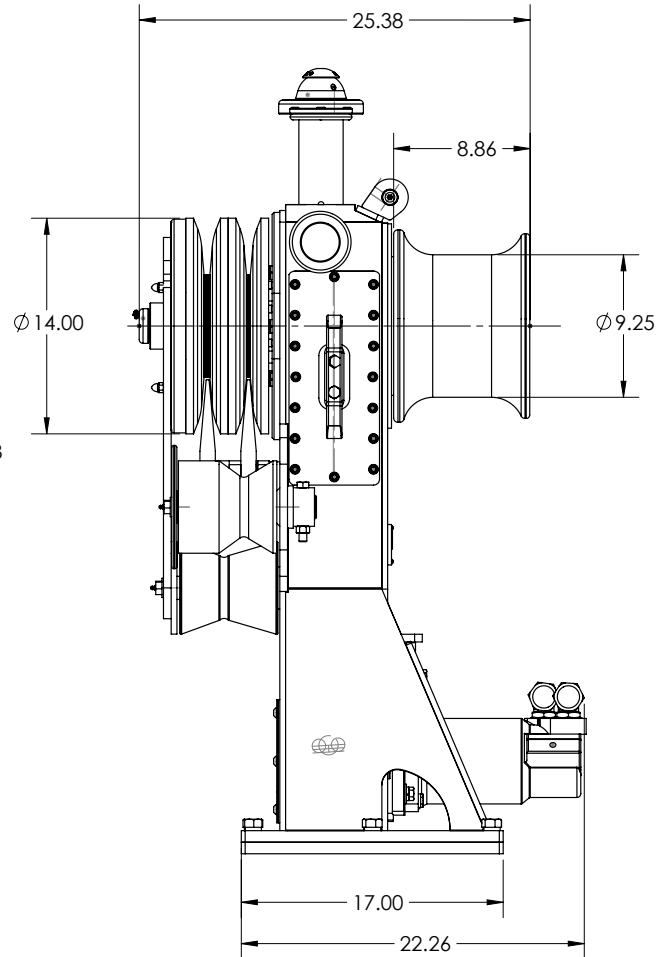
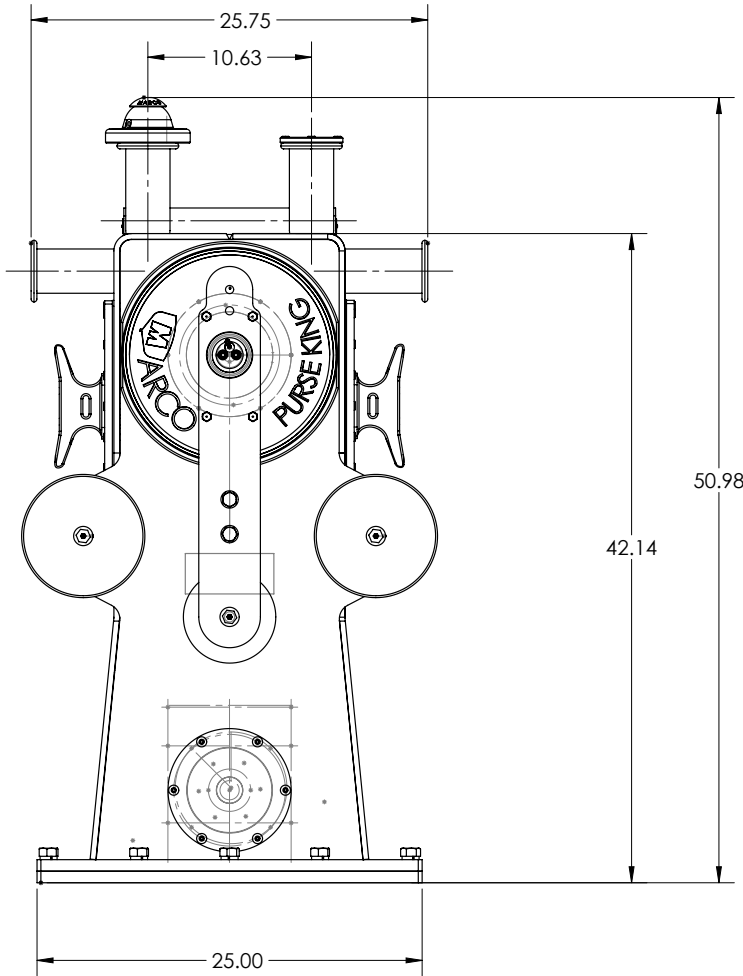

Weight: 1,000 lbs

Smith Berger Marine, Inc.

7915 10th Ave. S., Seattle, WA 98108 USA

Tel. 206.764.4650 - Toll Free 888.726.1688 - Fax 206.764.4653

E-mail: sales@smithberger.com - Web: www.smithberger.com